

ELECTRIC HEATERS

09160 Fireball Turbofan 3000

A highly yet portable electric fan heater. Perfect for small garages, workshops, offices and domestic use from a 13amp plug.

- 3000w (10,200BTU/hr) heat output
- Thermostatically controlled
- Highly portable - weighs just 4.8kg
- Turbofan design
- Heavy duty painted finish
- Cooling fan facility

trade level ★★

13 AMP SUPPLY

10,200BTU
HEAT
OUTPUT

ITEM NO.	09160
Supply	230v (13amp)
Heat Output	10,200 BTU/hr (3kW)
Net Weight	4.8kg
Gross Weight	5.2kg
Packaged Dimensions (HxWxL)	340 x 260 x 260mm
Barcode Number	5012713091607

09293 Fireball Turbofan 9000

Super powerful, this 9000w industrial electric fan heater is thermostatically controlled. No fumes, odour or humidity. Perfect for workshops, garages and factories.

- Thermostatically controlled
- Turbofan design
- Cooling fan facility

industrial level ★★★★★

3 PHASE SUPPLY

30,706BTU
HEAT
OUTPUT

ITEM NO.	09293
Supply	400v (16amp) - 3 ph
Heat Output	30,706 BTU/hr (9kW)
Heat Levels	52 / 4500 / 9000w
Net Weight	42kg
Gross Weight	52kg
Packaged Dimensions (HxWxL)	470 x 340 x 410mm
Barcode Number	5012713092932

Fireball Electric Heaters

Tough infrared and ceramic emitters - heat objects and not the surrounding atmosphere.

- Clean source of heating
- No Fan - minimal dust disturbance making these ideal for workshops
- Lightweight and portable

trade level ★★



10,200BTU
HEAT
OUTPUT



9,600BTU
HEAT
OUTPUT

DESCRIPTION	FIREBALL 37 INFRARED CERAMIC	FIREBALL 47 INFRARED QUARTZ
ITEM NO.	09193	09195
Supply	230v (13amp)	230v (13amp)
Element	Ceramic	Quartz
Heat Levels	2	2
Heat Output (min)	4,781 BTU/hr (1.4kW)	5,122 BTU/hr (1.5kW)
Heat Output (max)	9,600 BTU/hr (2.8kW)	10,200 BTU/hr (3kW)
Wheel Mounted	✗	✓
Net Weight	6.5kg	16kg
Gross Weight	7.4kg	18kg
Packaged Dimensions (HxWxL)	430 x 210 x 480mm	640 x 590 x 340mm
Barcode Number	5012713091607	5012713091607

INFRARED HEATERS - Diesel / Paraffin

09579 Firearay 70XRDT Infrared Diesel/Paraffin

trade level ★★

- Infrared - heats objects rather than the surrounding air
- Thermostatic control
- Easy-to-read LED temperature display panel
- Runs on diesel or paraffin
- Heavy duty painted finish



LED temperature display panel



70,000BTU
HEAT
OUTPUT

12 Litre
FUEL TANK

13 AMP
SUPPLY

ITEM NO.	09579
Supply	230v (13amp)
Heat Output	70,000 BTU/hr (20.5kW)
Fuel Consumption	1.4 litres/hr
Fuel Tank Capacity	12 litres
Net Weight	14.3kg
Gross Weight	16kg
Packaged Dimensions (HxWxL)	555 x 335 x 575mm
Barcode Number	5012713095797

09156 Fireball 1850 Infrared Diesel/Paraffin

industrial level ★★★★★

- 230v (13amp) supply
- 155,737 BTU (45.5Kw) heat output
- Heavy duty rugged construction
- 65 litre shockproof polythene fuel tank - reduces fuel contamination
- Infrared - heats objects rather than surrounding air
- Adjustable head for directing heat
- Timed post ventilation to cool the combustion chamber
- External structure in double sheet steel to ensure thermal and acoustic insulation



Integrated heat deflector,
protects flooring



155,000BTU
HEAT
OUTPUT

65 Litre
FUEL TANK

WHEEL
MOUNTED

13 AMP
SUPPLY

ITEM NO.	09156
Supply	230v (13amp)
Heat Output	155,737 BTU/hr (45.5kW)
Fuel Consumption	3.6 kg/hr 4.3 litres/hr
Fuel Tank Capacity	65 litres
Net Weight	75kg
Gross Weight	93kg
Packaged Dimensions (HxWxL)	1030 x 710 x 1040mm
Barcode Number	5012713091560

Patented
Design



PROPANE HEATERS

key features

Our fantastic new range of propane heaters are super value. With integrated safety grille and heavy duty powder coating, they are perfect for industrial, agricultural and automotive environments.

09287 Fireball 342 Propane

trade level ★★

- Powerful 34,121 BTU/hr (10kW) heat output
- Maximum 230m³ (8,122 cu.ft) approx. heating area
- Heavy duty painted finish
- Highly portable

NEW
FROM SIP



13 AMP
SUPPLY

ITEM NO.	09287
Supply	230v (13amp)
Heat Output	34,121 BTU/hr (10kW)
Approx. Heating Area	230m ³ (8122 cu.ft)
Fuel Consumption	0.73 kg/hr
Net Weight	3.8kg
Gross Weight	4.5kg
Packaged Dimensions (HxWxL)	430 x 210 x 310mm
Barcode Number	5012713092871

09288 Fireball 512 Propane

trade level ★★

- Powerful 51,182 BTU/hr (15kW) heat output
- Maximum 345m³ (12,181 cu.ft) approx. heating area
- Heavy duty painted finish
- Highly portable

NEW
FROM SIP



13 AMP
SUPPLY

ITEM NO.	09288
Supply	230v (13amp)
Heat Output	51,182 BTU/hr (15kW)
Approx. Heating Area	345m ³ (12,181 cu.ft)
Fuel Consumption	1.09 kg/hr
Net Weight	3.8kg
Gross Weight	4.5kg
Packaged Dimensions (HxWxL)	430 x 210 x 310mm
Barcode Number	5012713092888

09289 Fireball 1030 Propane

trade level ★★

- Powerful 102,364 BTU/hr (30kW) heat output
- Maximum 690m³ (24,367 cu.ft) approx. heating area
- Heavy duty painted finish
- Highly portable

NEW
FROM SIP



13 AMP
SUPPLY

ITEM NO.	09289
Supply	230v (13amp)
Heat Output	102,364 BTU/hr (30kW)
Approx. Heating Area	690m ³ (24,367 cu.ft)
Fuel Consumption	2.18 kg/hr
Net Weight	6.1kg
Gross Weight	7kg
Packaged Dimensions (HxWxL)	520 x 250 x 390mm
Barcode Number	5012713092895

09291 Fireball 1706 Propane

trade level ★★

- Powerful 170,607 BTU/hr (50kW) heat output
- Maximum 1145m³ (40,435 cu.ft) approx. heating area
- Heavy duty painted finish
- Highly portable

NEW
FROM SIP



13 AMP
SUPPLY

ITEM NO.	09291
Supply	230v (13amp)
Heat Output	170,607 BTU/hr (50kW)
Approx. Heating Area	1145m ³ (40,435 cu.ft)
Fuel Consumption	3.63 kg/hr
Net Weight	6.9kg
Gross Weight	7.9kg
Packaged Dimensions (HxWxL)	580 x 250 x 410mm
Barcode Number	5012713092918

key features

Made in Italy, these heaters boast fantastic performance coupled with outstanding value for money. These powder coated professional models are covered by a 2 year warranty. Perfect for industrial, agricultural and automotive environments.

09281 Professional Fireball 365 Propane

- Powerful 36,500 BTU/hr (10.7kW) heat output
- Maximum 245m³ (8652 cu.ft) approx. heating area
- Heavy duty painted finish
- Highly portable



professional level ★★★

2 YEAR WARRANTY 13 AMP SUPPLY

ITEM NO.	09281
Supply	230v (13amp)
Heat Output	36,500 BTU/hr (10.7kW)
Approx. Heating Area	245m ³ (8652 cu.ft)
Fuel Consumption	0.653 kg/hr
Gross Weight	5.5kg
Packaged Dimensions (HxWxL)	225 x 275 x 390mm
Barcode Number	5012713092819

09282 Professional Fireball 635 Propane

- Powerful 38,841 - 63,500 BTU/hr (11.4 - 18.6kW) heat output
- Maximum 426m³ (15,044 cu.ft) approx. heating area
- Heavy duty painted finish
- Highly portable



professional level ★★★

2 YEAR WARRANTY 13 AMP SUPPLY

ITEM NO.	09282
Supply	230v (13amp)
Heat Output	38,841 - 63,500 BTU/hr (11.4 - 18.6kW)
Approx. Heating Area	426m ³ (15,044 cu.ft)
Fuel Consumption	0.744 - 1.213 kg/hr
Gross Weight	5.9kg
Packaged Dimensions (HxWxL)	225 x 275 x 445mm
Barcode Number	5012713092826

09283 Professional Fireball 1070 Propane

- Powerful 51,787 - 107,000 BTU/hr (15.2 - 31.4kW) heat output
- Maximum 718m³ (25,355 cu.ft) approx. heating area
- Heavy duty painted finish
- Highly portable



Don't Forget WHEEL KIT Page 133



professional level ★★★

2 YEAR WARRANTY 13 AMP SUPPLY

ITEM NO.	09283
Supply	230v (13amp)
Heat Output	51,787 - 107,000 BTU/hr (15.2 - 31.4kW)
Approx. Heating Area	718m ³ (25,355 cu.ft)
Fuel Consumption	1.004 - 2.014 kg/hr
Gross Weight	13.1kg
Packaged Dimensions (HxWxL)	315 x 385 x 545mm
Barcode Number	5012713092833

09284 Professional Fireball 1600 Propane

- Powerful 74,202 - 160,000 BTU/hr (21.7 - 46.9kW) heat output
- Maximum 1074m³ (37,927 cu.ft) approx. heating area
- Heavy duty painted finish
- Highly portable



Don't Forget WHEEL KIT Page 133



professional level ★★★

2 YEAR WARRANTY 13 AMP SUPPLY

ITEM NO.	09284
Supply	230v (13amp)
Heat Output	74,202 - 160,000 BTU/hr (21.7 - 46.9kW)
Approx. Heating Area	1074m ³ (37,927 cu.ft)
Fuel Consumption	1.454 - 2.979 kg/hr
Gross Weight	14.7kg
Packaged Dimensions (HxWxL)	320 x 385 x 605mm
Barcode Number	5012713092840

PROFESSIONAL PROPANE HEATERS

key features

Made in Italy, these heaters boast fantastic performance coupled with outstanding value for money. These stainless steel professional models feature a front grille and are covered by a 2 year warranty. Perfect for industrial, agricultural and automotive environments.

09272 Professional Fireball 366 Propane

professional level ★★★

- Powerful 36,500 BTU/hr (10.7kW) heat output
- Maximum 245m³ (8652 cu.ft) approx. heating area
- Rugged corrosion resistant stainless steel casing - for tough daily use
- Highly portable



2 YEAR WARRANTY

13 AMP SUPPLY

STAINLESS STEEL

ITEM NO.	09272
Supply	230v (13amp)
Heat Output	36,500 BTU/hr (10.7kW)
Approx. Heating Area	245m ³ (8652 cu.ft)
Fuel Consumption	0.653 kg/hr
Gross Weight	5.5kg
Packaged Dimensions (HxWxL)	225 x 275 x 390mm
Barcode Number	5012713092727

09273 Professional Fireball 636 Propane

professional level ★★★

- Powerful 38,841 - 63,500 BTU/hr (11.4 - 18.6kW) heat output
- Maximum 426m³ (15,044 cu.ft) approx. heating area
- Rugged corrosion resistant stainless steel casing - for tough daily use
- Highly portable



2 YEAR WARRANTY

13 AMP SUPPLY

STAINLESS STEEL

ITEM NO.	09273
Supply	230v (13amp)
Heat Output	38,841 - 63,500 BTU/hr (11.4 - 18.6kW)
Approx. Heating Area	426m ³ (15,044 cu.ft)
Fuel Consumption	0.744 - 1.213 kg/hr
Gross Weight	5.9kg
Packaged Dimensions (HxWxL)	225 x 275 x 445mm
Barcode Number	5012713092734

09274 Professional Fireball 1071DV Propane

professional level ★★★

- 230v (13amp) / 110v
- Powerful 51,787 - 107,000 BTU/hr (15.2 - 31.4kW) heat output
- Maximum 718m³ (25,355 cu.ft) approx. heating area
- Rugged corrosion resistant stainless steel casing - for tough daily use
- Highly portable
- Dual voltage for optimum versatility



Don't Forget WHEEL KIT Page 133

2 YEAR WARRANTY

DUAL VOLTAGE

STAINLESS STEEL

ITEM NO.	09274
Supply	230v (13amp) / 110v
Heat Output	51,787 - 107,000 BTU/hr (15.2 - 31.4kW)
Approx. Heating Area	718m ³ (25,355 cu.ft)
Fuel Consumption	1.004 - 2.014 kg/hr
Gross Weight	13.1kg
Packaged Dimensions (HxWxL)	315 x 385 x 545mm
Barcode Number	5012713092741

09275 Professional Fireball 1602DV Propane

professional level ★★★

- 230v (13amp) / 110v
- Powerful 74,202 - 160,000 BTU/hr (21.7 - 46.9kW) heat output
- Maximum 1074m³ (37,927 cu.ft) approx. heating area
- Rugged corrosion resistant stainless steel casing - for tough daily use
- Highly portable
- Dual voltage for optimum versatility



Don't Forget WHEEL KIT Page 133

2 YEAR WARRANTY

DUAL VOLTAGE

STAINLESS STEEL

ITEM NO.	09275
Supply	230v (13amp) / 110v
Heat Output	74,202 - 160,000 BTU/hr (21.7 - 46.9kW)
Approx. Heating Area	1074m ³ (37,927 cu.ft)
Fuel Consumption	1.454 - 2.979 kg/hr
Gross Weight	14.7kg
Packaged Dimensions (HxWxL)	320 x 385 x 605mm
Barcode Number	5012713092758

PROFESSIONAL PROPANE HEATERS

09276 Professional Fireball 2261DV Propane

- 230v (13amp) / 110v supply
- Adjustable 106,995 - 226,000 BTU/hr (31.4 - 66.2kW) heat output
- Maximum 1517m³ (53,572 cu.ft) approx. heating area
- Rugged corrosion resistant stainless steel casing - for tough daily use
- Highly portable
- Dual voltage for optimum versatility



professional level ★★ ★

Don't Forget
WHEEL KIT
See Below

2 YEAR WARRANTY

DUAL VOLTAGE

STAINLESS STEEL

ITEM NO.	09276
Supply	230v (13amp) / 110v
Heat Output (adjustable)	106,995 - 226,000 BTU/hr (31.4 - 66.2kW)
Approx. Heating Area	1517m ³ (53,572 cu.ft)
Fuel Consumption	2.097 - 4.268 kg/hr
Gross Weight	17.2kg
Packaged Dimensions (HxWxL)	355 x 430 x 630mm
Barcode Number	5012713092765

09277 Professional Fireball 2901DV Propane

- 230v (13amp) / 110v supply
- Adjustable 130,277 - 290,000 BTU/hr (38.2 - 85kW) heat output
- Maximum 1946m³ (68,722 cu.ft) approx. heating area
- Rugged corrosion resistant stainless steel casing - for tough daily use
- Highly portable
- Dual voltage for optimum versatility



Don't Forget
WHEEL KIT
See Below

2 YEAR WARRANTY

DUAL VOLTAGE

STAINLESS STEEL

ITEM NO.	09277
Supply	230v (13amp) / 110v
Heat Output (adjustable)	130,277 - 290,000 BTU/hr (38.2 - 85kW)
Approx. Heating Area	1946m ³ (68,722 cu.ft)
Fuel Consumption	2.514 - 5.275 kg/hr
Gross Weight	19.2kg
Packaged Dimensions (HxWxL)	345 x 435 x 735mm
Barcode Number	5012713092772

09278 Professional Fireball 3711DV Propane

- 230v (13amp) / 110v supply
- Adjustable 158,767 - 371,000 BTU/hr (46.5 - 108.7kW) heat output
- Maximum 2490m³ (87,934 cu.ft) approx. heating area
- Rugged corrosion resistant stainless steel casing - for tough daily use
- Highly portable
- Dual voltage for optimum versatility



2 YEAR WARRANTY

DUAL VOLTAGE

STAINLESS STEEL

WHEEL MOUNTED

ITEM NO.	09278
Supply	230v (13amp) / 110v
Heat Output	158,767 - 371,000 BTU/hr (46.5 - 108.7kW)
Approx. Heating Area	2490m ³ (87,934 cu.ft)
Fuel Consumption	3.094 - 6.899 kg/hr
Gross Weight	28.5kg
Packaged Dimensions (HxWxL)	465 x 465 x 840mm
Barcode Number	5012713092789

09285 Fireball Wheel Kit

For models:
Fireball 1070, 1600, 1071DV, 1602DV and 2261DV

- Increased manoeuvrability
- Allows multiple heaters to be stacked in showroom displays

Barcode Number: 5012713092857

09286 Fireball Wheel Kit

For Fireball 2901DV

- Increased manoeuvrability
- Allows multiple heaters to be stacked in showroom displays

Barcode Number: 5012713092864



09285



09286



units can be stacked for showroom displays

DIESEL / PARAFFIN HEATERS

key features

These powerful, bright orange, hard wearing heaters run from diesel/paraffin/kerosene. With a heavy duty painted finish, they are ideal for heating workshops, farm buildings and garages.



Built-in thermostat and digital temperature read-out.

(on items: 09562, 09564, 09566, 09568 and 09570)

09560 Fireball 50XD Diesel

- 230v (13amp) supply
- 50,000 BTU (14.7kW) heat output
- Heavy duty painted finish
- 20 litre capacity fuel tank



trade level ★★

13 AMP SUPPLY

ITEM NO.	09560
Supply	230v (13amp)
Heat Output	50,000 BTU/hr (14.7kW)
Approx. Heating Area	350m ³ (12,360 cu.ft)
Fuel Tank Capacity	20 litres
Fuel Consumption	1.5 litre/hr
Weight	17.7kg
Packaged Dimensions (HxWxL)	405 x 330 x 790mm
Barcode Number	5012713095605

09562 Fireball 75XD

- 230v (13amp) supply
- 75,000 BTU (22kW) heat output
- Heavy duty painted finish
- 20 litre capacity fuel tank



trade level ★★

09563 Wheel Kit

Optional wheel kit to fit Fireball 75XD
Barcode No: 5012713095636

Don't Forget
WHEEL
KIT



13 AMP SUPPLY

ITEM NO.	09562
Supply	230v (13amp)
Heat Output	75,000 BTU/hr (22kW)
Approx. Heating Area	530m ³ (18,717 cu.ft)
Fuel Tank Capacity	20 litres
Fuel Consumption	2 litre/hr
Weight	16.5kg
Packaged Dimensions (HxWxL)	405 x 330 x 790mm
Barcode Number	5012713095629



Easy to read fuel gauge.
(on items: 09562, 09564, 09566,
09568 and 09570)

09564 Fireball 100XD

- 230v (13amp) supply • 100,000 BTU (29.3kW) heat output
- Heavy duty painted finish
- 40 litre capacity fuel tank
- Wheel mounted
- Pneumatic tyres



trade level ★★

13 AMP SUPPLY

WHEEL MOUNTED

ITEM NO.	09564
Supply	230v (13amp)
Heat Output	100,000 BTU/hr (29.3kW)
Approx. Heating Area	700m ³ (24,720 cu.ft)
Fuel Tank Capacity	40 litres
Fuel Consumption	2.8 litre/hr
Weight	24kg
Packaged Dimensions (HxWxL)	565 x 380 x 890mm
Barcode Number	5012713095643

09566 Fireball 125XD

- 230v (13amp) supply
- 125,000 BTU (36.6kW) heat output
- Heavy duty painted finish
- 40 litre capacity fuel tank
- Wheel mounted
- Pneumatic tyres



trade level ★★

13 AMP SUPPLY

WHEEL MOUNTED

ITEM NO.	09566
Supply	230v (13amp)
Heat Output	125,000 BTU/hr (36.6kW)
Approx. Heating Area	900m ² (31,783 cu.ft)
Fuel Tank Capacity	40 litres
Fuel Consumption	4 litre/hr
Weight	26.8kg
Packaged Dimensions (HxWxL)	565 x 380 x 890mm
Barcode Number	5012713095667

09568 Fireball 175XD

- 230v (13amp) supply
- 175,000 BTU (51.3kW) heat output
- Heavy duty painted finish
- 50 litre capacity fuel tank
- Wheel mounted
- Pneumatic tyres



trade level ★★

13 AMP SUPPLY

WHEEL MOUNTED

ITEM NO.	09568
Supply	230v (13amp)
Heat Output	175,000 BTU/hr (51.3kW)
Approx. Heating Area	1230m ² (43,437 cu.ft)
Fuel Tank Capacity	50 litres
Fuel Consumption	5 litre/hr
Weight	31kg
Packaged Dimensions (HxWxL)	565 x 435 x 1035mm
Barcode Number	5012713095681

09570 Fireball 215XD

- 230v (13amp) supply
- 215,000 BTU (63kW) heat output
- Heavy duty painted finish
- 50 litre capacity fuel tank
- Wheel mounted
- Pneumatic tyres



trade level ★★

13 AMP SUPPLY

WHEEL MOUNTED

ITEM NO.	09570
Supply	230v (13amp)
Heat Output	215,000 BTU/hr (63kW)
Approx. Heating Area	1500m ² (52,972 cu.ft)
Fuel Tank Capacity	50 litres
Fuel Consumption	6.5 litre/hr
Weight	33kg
Packaged Dimensions (HxWxL)	565 x 435 x 1035mm
Barcode Number	5012713095704



Search YouTube for:
SipTechZone

PROFESSIONAL DIESEL / PARAFFIN HEATERS

key features

Powerful, diesel space heaters - ideal for heating factories, warehouses, garages, farms and workshops. Can be used with paraffin or diesel without setting adjustments.

- Extra thick stainless steel for prolonged life
- Designed to be one of the most reliable heaters on the market
- External fuel filter means less downtime and improved reliability
- Unique plastic composite fuel tank for long life and less fuel contamination
- Pump system made by Danfoss of Denmark
- European made - top quality
- Two year warranty



Search YouTube for:
SipTechZone

- 09041 **Fireball 660S** diesel/paraffin
- 09047 **Fireball 1645S** diesel/paraffin

professional level ★★ ★



Automatic control panel for ease of use

heating

146

THE MOST RELIABLE HEATER RANGE ON THE MARKET!

2 Year Warranty

2 YEAR WARRANTY

13 AMP SUPPLY

STAINLESS STEEL



PRODUCT NAME	Fireball 660S	Fireball 1645S
ITEM NO.	09041	09047
Supply	230v (13amp)	230v (13amp)
Heat Output	73,110 BTU/hr (21.4kW)	164,850 BTU/hr (49.0kW)
Approx. Heating Area	461m ³ (16,400 cu.ft)	1154m ³ (41,214 cu.ft)
Fuel Consumption	1.69 kg/hr	3.88 kg/hr
Fuel Tank Capacity	2.1 litres/hr	4.81 litres/hr
Weight	17 litres	42 litres
Packaged Dimensions (HxWxL)	20kg	39kg
Barcode Number	445 x 300 x 740mm	560 x 400 x 1030mm
	5012713090419	5012713090471

09001 Wheel Kit

Optional wheel kit to fit Fireball 660S
Barcode Number: 501271309001



09034 Thermostat

Optional thermostat for use with Fireball 1645S (09047)

- 10 metre cable

Barcode Number: 501271309001



PROFESSIONAL DIESEL / PARAFFIN HEATERS

Range Feature - Professional Diesel / Paraffin Heaters



Electrode - Fuel Nozzles
Snap on deflector allows immediate access to fuel nozzles & electrodes



Burner
Designed to ensure a perfect air-fuel mixture, resulting in an almost total combustion, with a CO₂ level of Oppm



Fan - Danfloss Fuel Pump
To enhance performance of the fan a shroud unit has been added to provide a ducted fan.

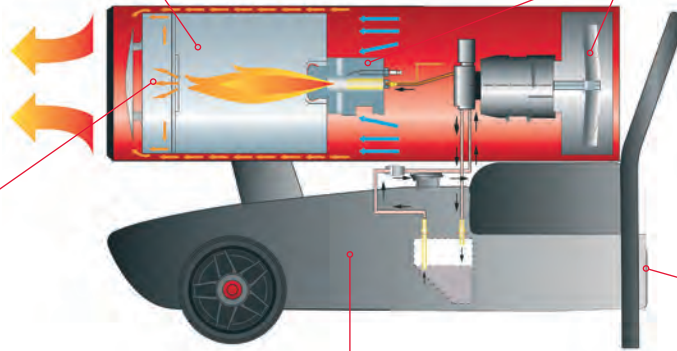

Combustion Chamber
Manufactured from AISI 430 stainless steel with aluminised steel heat exchangers for better cooling



Fuel Tank
Tough hydrocarbon resistant polythene construction containing special additives for use in particularly cold environments



Control Panel
Tough flame proof plastic, built into fuel tank to ensure no infiltration of water, dust, etc...

SIP Heater - Heating Area Comparison Chart

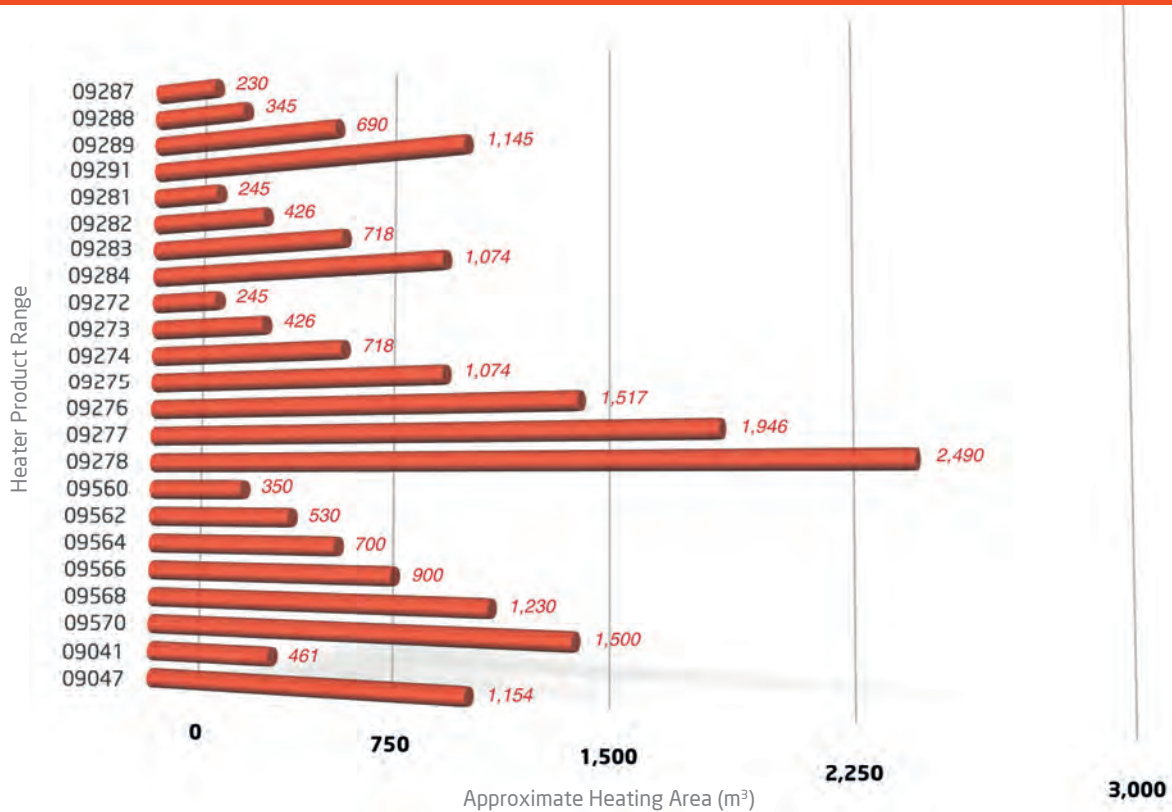

HITON - UNIVERSAL OIL BURNING HEATERS

key features

A fantastic range of efficient, clean, virtually soot free combustion solutions using waste oil or diesel. The furnace will operate using most engine oils; mineral, synthetic as well as gear and hydraulic oils.

Made in the EU for superior quality, our Hiton oil heaters all include a flue kit.

- 09159 **Hiton HP105 Oil Heater**
- 09177 **Hiton HP115 Oil Heater**
- 09161 **Hiton HP125-O Oil Heater**
- 09178 **Hiton HP125 Oil Heater**



**75,067 BTU/hr
MAX. HEAT
OUTPUT**

09159



**75,067 BTU/hr
MAX. HEAT
OUTPUT**

09177

**FREE
FLUE KIT INCLUDED
WITH ALL HITON
HEATERS**



**13 AMP
SUPPLY**

PRODUCT NAME	HP105	HP115	H125-O	HP125
ITEM NO.	09159	09177	09161	09178
Supply	230v (13amp)	230v (13amp)	230v (13amp)	230v (13amp)
Min. Heat Output	51,182 BTU/hr (15kW)	51,182 BTU/hr (15kW)	72,000 BTU/hr (21kW)	72,000 BTU/hr (21kW)
Max. Heat Output	75,067 BTU/hr (22kW)	75,067 BTU/hr (22kW)	102,420 BTU/hr (30kW)	102,420 BTU/hr (30kW)
Approx. Heating Area	420m ³ (14,832 cu.ft)	420m ³ (14,832 cu.ft)	668m ³ (24,297 cu.ft)	668m ³ (24,297 cu.ft)
Fuel Consumption (min. output)	1.25 kg/hr (1.49 ltr/hr)	1.25 kg/hr (1.49 ltr/hr)	1.8 kg/hr (2.14 ltr/hr)	1.8 kg/hr (2.14 ltr/hr)
Fuel Consumption (max. output)	1.85 litres/hr (2.20 ltr/hr)	1.85 litres/hr (2.20 ltr/hr)	2.9 litres/hr (3.44 ltr/hr)	2.9 litres/hr (3.44 ltr/hr)
Fuel Tank Capacity	50 litres	50 litres	50 litres	50 litres
Finish	Heavy Duty Painted	Heavy Duty Painted	Galvanised Metal	Heavy Duty Painted
Flue Diameter Ø	150mm	150mm	150mm	150mm
Flue Included	✓	✓	✓	✓
Fan Assisted	✗	✓	✓	✓
Weight	70kg	90kg	90kg	90kg
Packaged Dimensions (HxWxL)	1140 x 540 x 780mm	1340 x 540 x 780mm	1360 x 540 x 780mm	1360 x 540 x 780mm
Barcode Number	5012713091591	50127130091775	5012713091614	5012713091614

HITON - UNIVERSAL OIL BURNING HEATERS

PLEASE NOTE:

In order to burn waste oil you will need to register with your local authority



09161



09178

heating

149



HITON - UNIVERSAL OIL BURNING HEATERS

09179 Hiton HP145 Oil Heater

The heater features a built-in heavy duty heat exchanger for increased output.



09179

143,406 BTU/hr
MAX HEAT OUTPUT



13 AMP SUPPLY

PRODUCT NAME	HP145
ITEM NO.	09179
Supply	230v (13amp)
Min. Heat Output	102,420 BTU/hr (30 kW)
Max. Heat Output	143,406 BTU/hr (42 kW)
Approx. Heating Area	2660m ³ (93,937 cu.ft)
Fuel Consumption (min. output)	2.55 kg/hr (3.04 ltr/hr)
Fuel Consumption (max. output)	3.57 litres/hr (4.25 ltr/hr)
Fuel Tank Capacity	50 litres
Finish	Heavy Duty Painted
Flue Diameter Ø	150mm
Flue Included	✓
Fan Assisted	✓
Weight	110kg
Packaged Dimensions (HxWxL)	1270 x 600 x 1200mm
Barcode Number	5012713091799

Hiton Universal Oil Heater Boosters

Item No: 09164 - Suitable for model: HP105, HP115 & HP125

Item No: 09171 - Suitable for model: HP145

These stainless steel heat boosters can increase your universal oil heater's output by 40% by utilising heat that would ordinarily be released and lost up through the flue.

The boosters are compatible with all of our universal oil heaters and simply slot in between the heater and the flue.

Use a heat booster and increase your oil heater's efficiency up to a massive 91%.

Barcode Number for 09164: 5012713091645

Barcode Number for 09171: 5012713091713

40% INCREASE IN OUTPUT

UP TO 90% EFFICIENCY



09164