

BOTTLE JACKS & JACK STANDS

key features

A range of compact and powerful bottle jacks, with built-in safety valves, screw extensions* to provide adjustable starting height and serrated saddles to give a secure contact with the load.

*not applicable to items 03671 & 03672

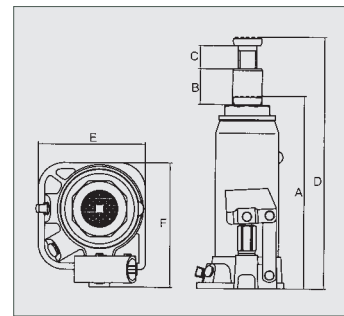

Trade Bottle Jack



ITEM NO.	BARCODE NO.	LIFTING CAPACITY (TON)	A (MM)	B (MM)	C (MM)	D (MM)	E (MM)	F (MM)	GROSS WEIGHT	PACKAGED DIMENSIONS
03666	5012713036660	2	156	100	60	320	93	88	2.3kg	120 x 100 x 175mm
03667	5012713036677	4	183	118	60	354	102	107	3.2kg	125 x 110 x 210mm
03668	5012713036684	8	202	136	60	400	120	117	5.4kg	140 x 130 x 210mm
03669	5012713036691	12	213	142	60	415	132	135	7.2kg	150 x 145 x 225mm
03670	5012713036707	20	242	166	60	470	140	154	11kg	180 x 165 x 255mm
03671	5012713036714	30	288	200	n/a	489	160	170	14.6kg	180 x 180 x 295mm
03672	5012713036721	50	298	200	n/a	494	176	214	33kg	240 x 220 x 320mm

Jack Stands

Our range of jack stands are strong and rugged. Supplied in pairs, all models have a large foot print to spread the load.

Choose from ratchet action or pin and chain height adjustment.



ITEM NO.	BARCODE NO.	DESCRIPTION	QTY SUPPLIED	LIFTING CAPACITY (TON)	LIFTING RANGE	HEIGHT ADJUSTMENT	GROSS WEIGHT	PACKAGED DIMENSIONS
03919	5012713039197	2 Ton Foldable Jack Stand	Pair	2	277 to 365mm	Pin and Chain	3.44kg	295 x 130 x 95mm
03826	5012713038262	3 Ton Jack Stand	Pair	3	238 to 372mm	Ratchet	7.2kg	360 x 220 x 220mm
03828	5012713038282	6 Ton Jack Stand	Pair	6	395 to 605mm	Ratchet	13.7kg	465 x 305 x 270mm
03842	5012713038428	6 Ton Extra Tall Jack Stands	Pair	6	570 to 900mm	Pin and Chain	22kg	725 x 455 x 435mm

03902 1.5 Ton Aluminium Racing Jack

Extra light weight - **only 12.5kg**. Aircraft grade aluminium construction.

- Patented design
- Single pump system for reliability
- Large saddle with rubber contact pad
- Side carry handle
- Single roller load wheel

trade level ★★



1.5 Ton
CAPACITY

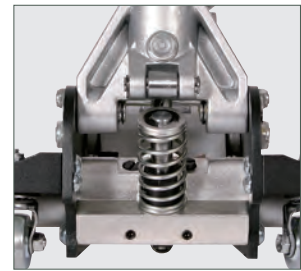

Single pump system

ITEM NO.	03902
Lifting Capacity	1.5 ton
Min. Height	86mm
Max. Height	375mm
Product Dimensions	555 x 250 x 150mm
Packaged Dimensions	590 x 290 x 175mm
Net Weight	12.5kg
Gross Weight	14kg
Barcode Number	5012713039029

03904 2.5 Ton Aluminium/Steel Racing Jack

Light weight aluminium and steel construction for strength and durability.

- Patented design
- Dual pump system for reliability
- Large saddle with rubber contact pad
- Side carry handle

trade level ★★



2.5 Ton
CAPACITY

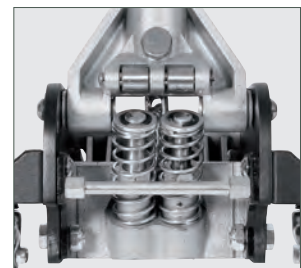

Dual pump system

ITEM NO.	03904
Lifting Capacity	2.5 ton
Min. Height	100mm
Max. Height	460mm
Product Dimensions	650 x 292 x 170mm
Packaged Dimensions	730 x 340 x 220mm
Net Weight	26.4kg
Gross Weight	28.2kg
Barcode Number	5012713039043

TROLLEY JACKS

03812 2 Ton Low Profile 'High Lift' Trolley Jack

trade level ★★

Extra low profile - ideal for low cars.

- Steel hydraulic assembly with dust seals to prevent oil contamination
- Removable two piece handle with rubber hand grip for ease of pumping
- Safety by-pass system protects pressure cylinder
- Heavy duty chassis for added strength and dependability



Don't Forget
HYDRAULIC OIL
Page 136

ITEM NO.	03812
Lifting Capacity	2 ton
Min. Height	76mm
Max. Height	510mm
Product Dimensions	1006 x 365 x 136mm
Packaged Dimensions	1060 x 420 x 210mm
Net Weight	42kg
Gross Weight	44kg
Barcode Number	5012713038121

2 Ton
CAPACITY

HIGH-LIFT
CAPACITY

126

03675 2.5 Ton Low Profile Service Jack

trade level ★★

- Low 93 to 490mm lifting height
- Extra low profile - great for low cars
- Steel hydraulic block assembly to prevent oil contamination
- Large saddle with rubber contact pad to prevent vehicle damage
- Removable two piece handle with rubber hand grip for ease of pumping
- Safety by-pass system protects pressure cylinder
- Heavy duty chassis

NEW
FROM SIP



Don't Forget
HYDRAULIC OIL
Page 136

ITEM NO.	03675
Lifting Capacity	2.5 ton
Min. Height	93mm
Max. Height	490mm
Packaged Dimensions	200 x 390 x 700mm
Net Weight	34kg
Gross Weight	36kg
Barcode Number	5012713036752

2.5 Ton
CAPACITY

03677 3 Ton Trolley Jack

trade level ★★

- Powerful and reliable automotive jack
- 135mm to 495mm lifting height
- Patented design
- Steel hydraulic assembly with dust seals
- Extra large saddle and rubber pad
- Heavy gauge base
- Heavy duty wheels and castors
- Extra strong long handle



NEW
FROM SIP

3 Ton
CAPACITY

ITEM NO.	03677
Lifting Capacity	3 ton
Min. Height	135mm
Max. Height	495mm
Packaged Dimensions	215 x 390 x 695mm
Net Weight	34kg
Gross Weight	35kg
Barcode Number	5012713036776

03676 3 Ton 'Quick Lift' Trolley Jack

trade level ★★

- 135 to 495mm lift height
- Steel hydraulic assembly includes dust seals to prevent oil contamination
- Removable two piece handle with rubber grip
- Single stroke foot pedal quickly raises saddle to the vehicle lift point
- Extra large saddle with rubber pad



NEW
FROM SIP

3 Ton
CAPACITY

QUICK-LIFT
FEATURE

ITEM NO.	03676
Lifting Capacity	3 ton
Min. Height	135mm
Max. Height	495mm
Packaged Dimensions	200 x 390 x 700mm
Net Weight	34kg
Gross Weight	35kg
Barcode Number	5012713036769

07256 3 Ton 'Fast Lift' Trolley Jack

professional level ★★★

Professional Omega™ lifting equipment.

- Extra large saddle with polyurethane pad - minimises vehicle chassis damage
- 'Fast-Lift' foot pedal quickly raises saddle to the vehicle lift point
- Patented hydraulic by-pass system, limits ram over-travel
- Polished hydraulic ram and cylinder to reduce abrasion and extend hydraulic seal life
- Heavy gauge construction for maximum strength and durability



FAST-LIFT
FEATURE

3 Ton
CAPACITY

ITEM NO.	07256
Lifting Capacity	3 ton
Min. Height	133mm
Max. Height	490mm
Product Dimensions	235 x 341 x 650mm
Packaged Dimensions	225 x 385 x 740mm
Net Weight	37.6kg
Gross Weight	38.8kg
Barcode Number	5012713072569

FLOOR JACKS

03870 **5 Ton Long 'Quick Liff' Floor Jack**

03872 **10 Ton Long 'Quick Liff' Floor Jack**

trade level ★★

Heavy duty long floor jacks with 'quick liff' foot pedal. The jacks include a one-piece handle, rear swivel castors and large saddle for easy under vehicle positioning.

- 'Quick Liff' pedal gives rapid initial lift to vehicle contact point
- Rear toe plate for easy positioning
- Extra large diameter saddle
- Extra long handle for easy access under large vehicles

Lifting & Automotive Equipment

128



both jacks feature an extra large diameter saddle

ITEM NO.	03870	03872
Lifting Capacity	5 ton	10 ton
Min. Height	150mm	160mm
Max. Height	560mm	560mm
Product Dimensions	1510 x 380 x 210mm	1640 x 480 x 260mm
Packaged Dimensions	1570 x 420 x 340mm	1670 x 520 x 300mm
Net Weight	87kg	146kg
Gross Weight	101kg	166kg
Barcode Number	5012713038701	5012713038725

AIR / PNEUMATIC FLOOR JACKS

03808 22 Ton Air Floor Jack

A professional, high performance air floor jack. Compact low profile design for maximum access, this jack is ideal for commercial vehicle applications.

- Heavy duty solid rubber wheels
- Pneumatic operating function
- Ground ram saddle
- Adaptor models supplied with 3 quick fit supports to increase starting height

trade level ★★



smooth and effortless operation

22 Ton
CAPACITY

ITEM NO.	03808
Lifting Capacity	22 ton
Min. Height	230mm
Max. Height	430mm
Ram Stroke	105mm
Screw Extension	105mm
Air Pressure	7.5 to 8.5 bar
Air Consumption	9.5 CFM
Packaged Dimensions	660 x 380 x 240mm
Net Weight	45.5kg
Gross Weight	47kg
Barcode Number	5012713038084

03917 20/40 Ton Pneumatic Truck Jack

A powerful and reliable pneumatic truck jack. Compact design for maximum access, ideal for use on trucks and other commercial vehicles.

- Powerful and reliable
- Large rubber wheels for improved manoeuvrability
- Compact lift assembly and long handle for maximum access
- Release safety handle
- Chrome plated ram cylinder - reduces abrasion and extends hydraulic seal life
- Air return - provides smoother return action

trade level ★★



convenient handle top control

20/40 Ton
CAPACITY

ITEM NO.	03917
Min. Height	170mm
Max. Height	437mm
Spacers / Extensions	75mm & 45mm
Stage 1 Ram Stroke	85mm
Stage 1 Capacity	40 Ton
Stage 2 Ram Stroke	62mm
Stage 2 Capacity	20 Ton
Packaged Dimensions	1660 x 370 x 320mm (box 1) 1480 x 350 x 120mm (box 2)
Net Weight	68kg
Barcode Number	5012713039173

BENCH & FLOOR PRESSES

key features

Ideal for the removal or installation of bearings, universal joints, pulleys, wrist pins and various other jobs. Perfect for bending, bonding and straightening.

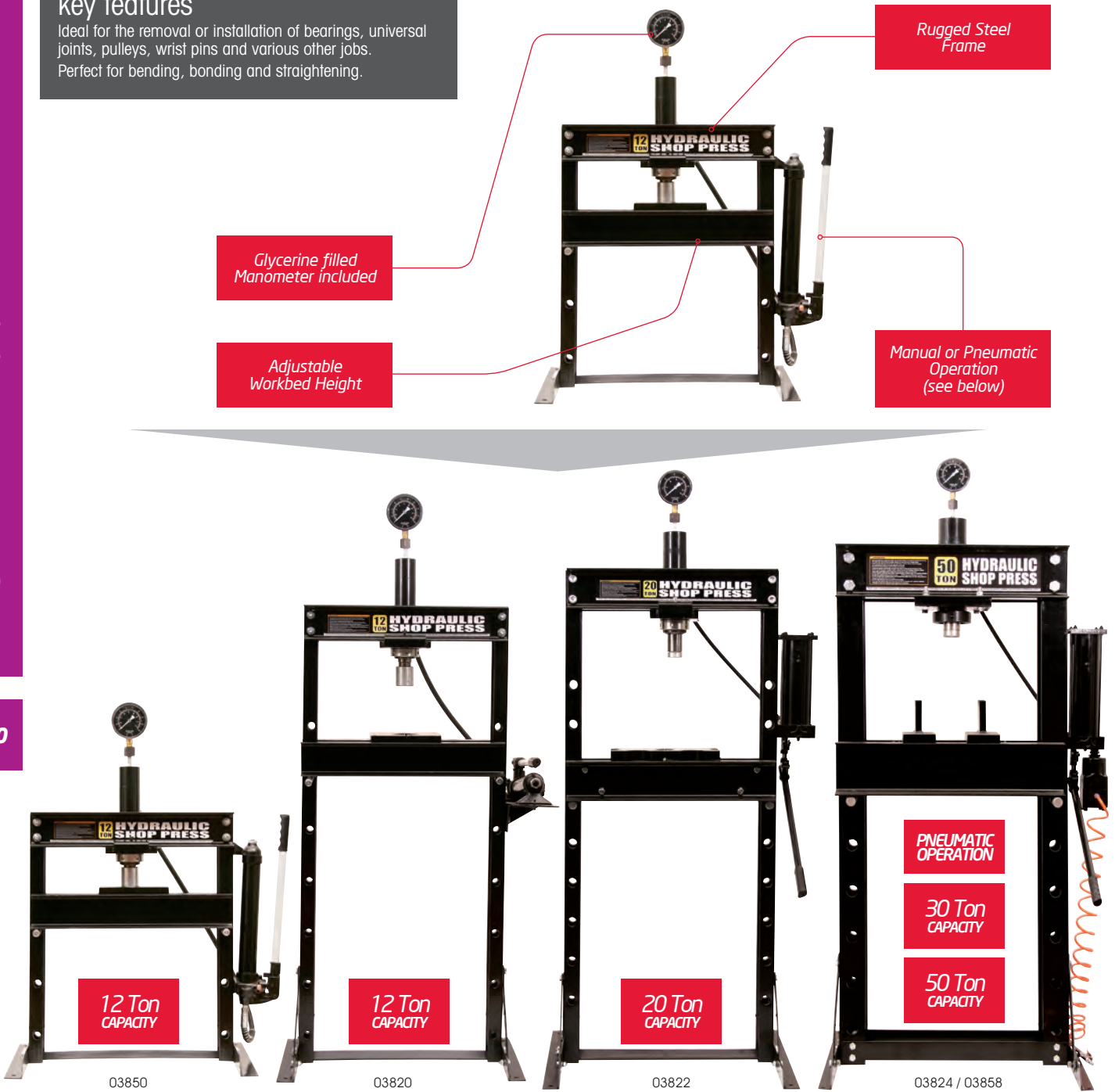

- 03850 **12 Ton Bench Press**
- 03820 **12 Ton Floor Press**
- 03822 **20 Ton Floor Press**
- 03824 **30 Ton Pneumatic Floor Press**
- 03858 **50 Ton Pneumatic Floor Press**

trade level ★★

All SIP presses feature:
 A rugged steel frame • Adjustable work bed height • Glycerine filled manometer
 Items 03824 & 03858 feature pneumatic operation

ITEM NO.	03850	03820	03822	03824	03858
Capacity	12 ton	12 ton	20 ton	30 ton	50 ton
Ram Stroke	175mm	175mm	185mm	160mm	175mm
Work Range	0 to 300mm	0 to 920mm	0 - 910mm	0 to 840mm	0 to 890mm
Product Dimensions	785 x 500 x 1060	1660 x 695 x 500	1800 x 820 x 700	865 x 700 x 1800	1650 x 850 x 800
Packaged Dimensions (HxWxL)	780 x 410 x 160	1375 x 165 x 195 (Box1) 660 x 220 x 150 (Box2)	1550 x 185 x 150 (Box1) 640 x 320 x 130 (Box2)	1656 x 380 x 300	1860 x 930 x 390
Net Weight	63kg	75kg	101kg	152kg	243kg
Barcode Number	5012713038503	5012713038206	5012713038220	5012713038244	5012713038589

03871 500kg Transmission Jack

- Oversized foot pedal for easy lifting
- Knurled air release valve
- Spring loaded pressure released valve
- Convenient foot pedal lifting

trade level ★★



Oversized foot pedal for easy lifting



Knurled pressure release valve

IMPROVED DESIGN

03869 Transmission Adaptor

- Fully adjustable gearbox support with forward, backward and side-to-side tilt
- For use with 03871



ITEM NO.	03871
Lifting Capacity	500kg
Min. Height	1175mm
Max. Height	1995mm
Packaged Dimensions	285 x 230 x 1125
Net Weight	30kg
Gross Weight	38kg
Barcode Number	5012713038718

03678 Adjustable Engine Support

trade level ★★

Suitable for work on most cars - soft rubber shoes to prevent car body damage

- 0.5 ton capacity • Double groove chain • Heavy duty design • Feet & twin spindles are adjustable over the whole length of the support
- Easy to position engine or gearbox • Fine adjustment by manual screw rod



ITEM NO.	03678
Max. Capacity	0.5 ton
Crossbeam Length	1500mm
Net Weight	22kg
Packaged Dimensions	1540 x 150 x 110mm
Gross Weight	24kg
Barcode	5012713036783

0.5 Ton CAPACITY

03862 Cross Beam Jack Adaptor

trade level ★★

- Gives extra safety for locating awkward jacking points
- 2 Ton capacity
- For use with items: 03810 & 03814



ITEM NO.	03862
Max. Capacity	2 tons
Pad Width Adjust	590mm to 930mm
Max. Pad Height Adjust	70mm
Packaged Dimensions	725 x 130 x 140mm
Net Weight	11.5kg
Gross Weight	12.5kg
Barcode Number	5012713038626

2 Ton CAPACITY

AUTOMOTIVE EQUIPMENT

03846 1 Ton Foldable Engine Crane

03847 2 Ton Foldable Engine Crane

trade level ★★

Foldable - retractable front legs and lifting boom for easy storage.

- 1 Ton Engine Crane - 03846**
- 2000mm maximum lift height
 - 4 hole position boom
 - Lift capacities: 250 / 500 / 750 / 1000kgs
 - 4 wheels for easy movement
 - 4 Ton ram

- 2 Ton Engine Crane - 03847**
- 2000mm maximum lift height
 - 4 hole position boom
 - Lift capacities: 500 / 1000 / 1500 / 2000kgs
 - 6 wheels for easy movement
 - 8 Ton ram

**1Ton or 2Ton
OPTIONS
AVAILABLE**



**680 KG
CAPACITY**

ITEM NO.	03848
Max. Capacity	680kg
Packaged Dimensions	445 x 64 x 190mm
Net Weight	5.5kg
Gross Weight	6kg
Barcode Number	5012713038480

ITEM NO.	03846	03847
Max. Capacity	1 ton	2 ton
Capacity Pos. 2	0.75 ton	1.5 ton
Capacity Pos. 3	0.5 ton	1 ton
Capacity Pos. 4	0.25 ton	0.5 ton
Packaged Dimensions	1637 x 385 x 200mm	880 x 610 x 90mm (Box 1) 1540 x 320 x 170mm (Box 2)
Net Weight	71kg	104.1kg
Gross Weight	75kg	33.3kg (Box 1) 78.2kg (Box 2)
Barcode Number	5012713038466	5012713038473

03848 Engine Leveller

- Ideal for car, van, truck and marine engines/gearboxes up to 680kgs
- Fine screw adjustment for levelling-off-centre loads quickly & easily
- Chains supplied
- Can be used with most cranes (up to 680kg capacity)



03681 750lbs Engine Stand

trade level ★★

- Professional heavy duty engine stand
- 750lbs capacity
- 360° rotating head to allow access to all parts of the engine
- Fully adjustable mounting arms
- 1x heavy duty castor and 2x wheels for easy movement



**750 lbs
CAPACITY**

ITEM NO.	03681
Max. Capacity	750lbs
Packaged Dimensions	875 x 195 x 190mm
Net Weight	18.5kg
Gross Weight	20kg
Barcode Number	5012713036813

00588 Boot Slider Gun

trade level ★★

Air operated tool opens up boots effortlessly and evenly for easy insertion on to the shaft, eliminating the need for lubrication.

- Suitable for flexible boots 15 to 115mm • 8 BAR (115psi) max. pressure
- 1/4" - 18NPT connection • Weighs only 2.2kg

Barcode Number: 5012713005888

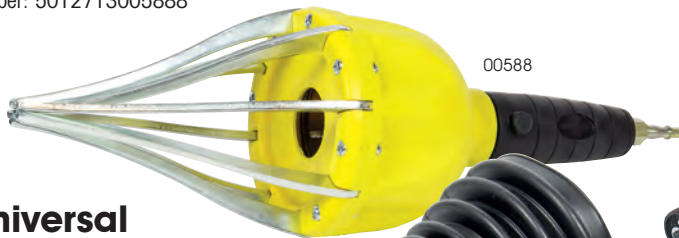

00592 Universal Flexible Boot

- For drive shafts: Ø 19 to 27mm
- CV joint sizes: Ø 58 to 105mm
- Temperature range: -40°C to 115°C
- Neoprene construction
- Contains: 1x boot, 1x 60g sachet of grease, 2x stainless steel ear clamps ties

Barcode Number: 5012713005925

00592



03903 Spring Compressor

trade level ★★

Fast and easy operation compared with other manual spring compressors

- 1000kg capacity
- 480mm maximum working length
- 325mm ram travel
- 4" - 10" spring sizes

1000 KG
CAPACITY

ITEM NO.	03903
Max. Capacity	1000kg
Max. Working Length	480mm
Ram Travel	325mm
Spring Ø Range	101.6mm to 254mm
Packaged Dimensions	1230 x 290 x 220mm
Net Weight	37kg
Gross Weight	39kg
Barcode Number	5012713039036



03836 60" Farm Jack

trade level ★★

- Heavy duty steel construction
- Large area base plate to spread load evenly
- Extra long 60" jacking beam

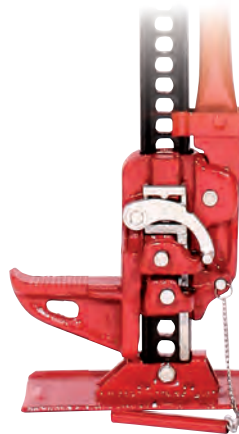

400 KG
CAPACITY

ITEM NO.	03836
Lifting Capacity	400kg
Min. Height	130mm
Max. Height	1325mm
Pad Size	115 x 35mm
Packaged Dimensions	1540 x 240 x 140mm
Net Weight	15kg
Gross Weight	16kg
Barcode Number	5012713038367



06449 Professional Torque Multiplier

professional level ★★★

Will loosen the tightest wheel nuts on trucks, agricultural machines and other heavy vehicles.

- 3500Nm maximum torque output • 1:56 high power ratio • Compact, robust and maintenance free
- Complete with 32mm and 33mm impact type sockets
- Supplied in blow moulded case



Storage/carry case



Additional Sockets

Individual sockets for use with 06449 Torque Multiplier.

- 60144 - 24mm
- 60146 - 27mm
- 60148 - 30mm
- 60147 - 32mm
- 60149 - 33mm
- 60150 - 36mm



ITEM NO.	06449
Max. Torque	3800Nm
Gear Ratio	1:58
Drive Size	1"
Packaged Dimensions	405 x 210 x 120mm
Net Weight	7.36kg
Gross Weight	8.64kg
Barcode Number	501271306496

AUTOMOTIVE EQUIPMENT

03816 4 Ton Auto Body Repair Kit

trade level ★★

Comprehensive kit specifically designed for autobody and machinery straightening and alignment.

- Polished hydraulic ram and cylinder to reduce abrasion
- Built in safety valve
- Supplied in sturdy steel storage/carry case
- 4 Ton Hand Pump, 4 Ton Ram, Hose, Spreader, Rubber Head, Rubber Faced Flat Base, Male Adaptor, Serrated Saddle, Plunger Toe, Ram Toe, Wedge Head, 90° Combination Head and Various Extension Tubes



ITEM NO.	03816
Ram Capacity	4 Tons
Min. Ram Length	330mm
Ram Stroke	120mm
Packaged Dimensions	580 x 240 x 168mm
Gross Weight	21kg
Barcode Number	5012713038169

4 Ton
CAPACITY

03679 10 Ton Auto Body Repair Kit

trade level ★★

Comprehensive kit specifically designed for autobody and machinery straightening and alignment.

- Polished hydraulic ram and cylinder to reduce abrasion
- Built in safety valve
- Supplied in sturdy steel storage/carry case
- 10 Ton Hand Pump, 10 Ton Ram, Hose, Spreader, Rubber Head, Flat Base, Male Adaptor, Serrated Saddle, Plunger Toe, Ram Toe, Wedge Head, 90° Combination Head and Various Extension Tubes



ITEM NO.	03679
Ram Capacity	10 Tons
Min. Ram Length	470mm
Ram Stroke	53mm
Packaged Dimensions	815 x 430 x 165mm
Gross Weight	36kg
Barcode Number	5012713036790

10 Ton
CAPACITY

03866 4 Ton Cable Puller

trade level ★★

- For moving vehicles, logs, machines and other heavy objects
- Double wheel & cable claw system
- Heavy duty steel construction
- 5mm cable diameter
- 3 metre cable length



ITEM NO.	03866
Pulling Capacity	4 Ton
Cable Length	3 metres
Cable Ø	5mm
Packaged Dimensions	710 x 280 x 160mm
Net. Weight	20kg
Gross Weight	22kg
Barcode Number	5012713038664

4 Ton
CAPACITY

03683 12 Ton Hydraulic Pipe Bender

trade level ★★

- Floor standing pipe bender with heavy duty steel chassis
- High quality 12 tonne hydraulic ram.
- External return springs.
- Suitable for bending pipe from Ø ½" up to Ø 2"
- Supplied with six formers for added versatility



12 Ton
CAPACITY

ITEM NO.	03683
Capacity	12 Ton
Former Sizes	½", ¾", 1", 1¼", 1½", 2"
Packaged Dimensions	640 x 430 x 125mm
Gross Weight	34.54kg
Barcode Number	5012713036837

03860 Car Wheel Dollies (Pair)

trade level ★★

- Pressed steel construction
- 4 heavy duty swivel castors for easy movement
- Capacity - 450kgs (per dolly)



450 KG
CAPACITY
(per dolly)

ITEM NO.	03860
Capacity	450kg (per dolly)
Product Dimensions	602 x 385 x 140mm
Packaged Dimensions	640 x 430 x 125mm
Net Weight	18kg (pair)
Gross Weight	18.5kg
Barcode Number	5012713038602

03912 Car Creeper

trade level ★★

- Oil resistant vinyl cover
- Fully padded back and adjustable angle head rest
- Solid rectangular frame for added strength
- 6 heavy duty swivel castors for optimum manoeuvrability



ITEM NO.	03912
Product Dimensions	1020 x 425 x 110mm
Packaged Dimensions	1040 x 440 x 125mm
Net Weight	7.2kg
Gross Weight	8.2kg
Barcode Number	5012713039128

AUTOMOTIVE EQUIPMENT

02347 **Advanced Hydraulic Oil 1 litre** *trade level* ★★

Specialist hydraulic oil developed specifically to meet the lubrication demands of most hydraulic applications

- High quality hydraulic oil
- Gives good flow rate
- Fully recyclable
- Anti-corrosion performance

Barcode Number: 5012713023479



03916 **Wheel Removal Trolley** *trade level* ★★

Perfect for taking off and mounting wheels on large vehicles e.g. tractors

- A convenient safe and easy way to handle large wheels
- Multiple rollers make this trolley very manoeuvrable
- 0 to 760mm wheel width range
- 1.2 Ton capacity



ITEM NO.	03916
Capacity	1.2 Tons
Max. Wheel Width	760mm
Packaged Dimensions	1300 x 1030 x 320mm
Net Weight	137kg
Gross Weight	157kg
Barcode Number	5012713039166

1.2 Ton CAPACITY

06886 **5 Gallon Parts Washer** *trade level* ★★

A large 23 litre (5 gallon) space saving bench top parts washer.

- 3.5 gallon fluid capacity
- Sturdy tough steel construction
- Lid fitted with fusible link for added safety
- 25w (230v) motor
- Pump rate 136 litres/hr (30 gallons)

Barcode Number: 5012713066869



13amp SUPPLY

03834 **20 Gallon Parts Washer** *trade level* ★★

A large 90 litre (20 gallon) space saving, floor standing parts washer.

- Sturdy tough steel construction
- Self latching lid with fusible link - snaps lid shut in the event of fire
- 25w (230v) motor
- Pump rate 136 litres/hr (30 gallons)
- Flexible metal nozzle for precise coverage

Barcode Number: 5012713038343



13amp SUPPLY